

Grundregal Étagère de base / Basisstelling / Basic rack / Scaffale base				
	①	4 x	⑩	4 x
	②	2 x	⑪	2 x
	③	4 x	⑫	4 x
	④	2 x	⑬	4 x
	⑤	1 x	⑭	6 x
	⑥	4 x	⑮	4 x
	⑦	2 x	⑯	24 x
	⑧	2 x	⑰	4 x
	⑨	2 x		

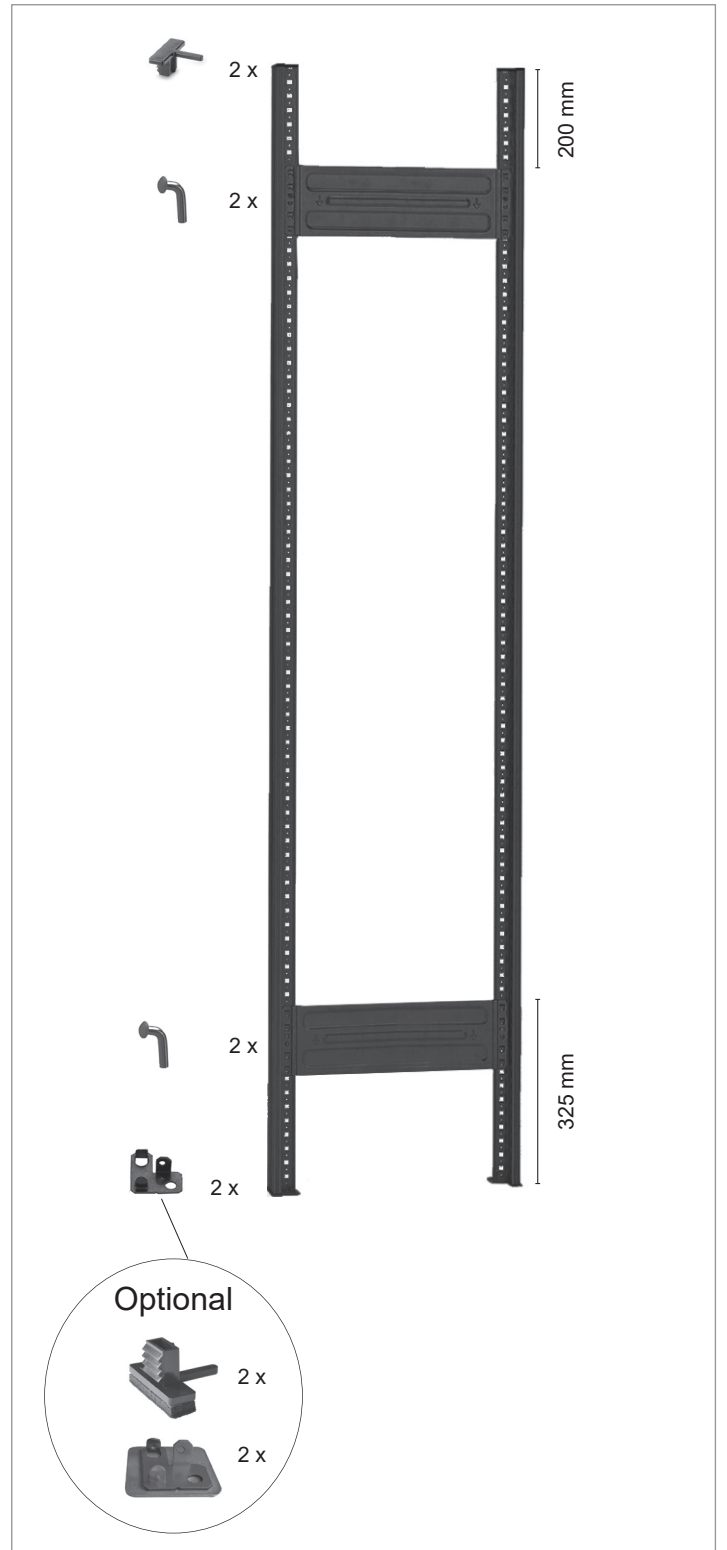

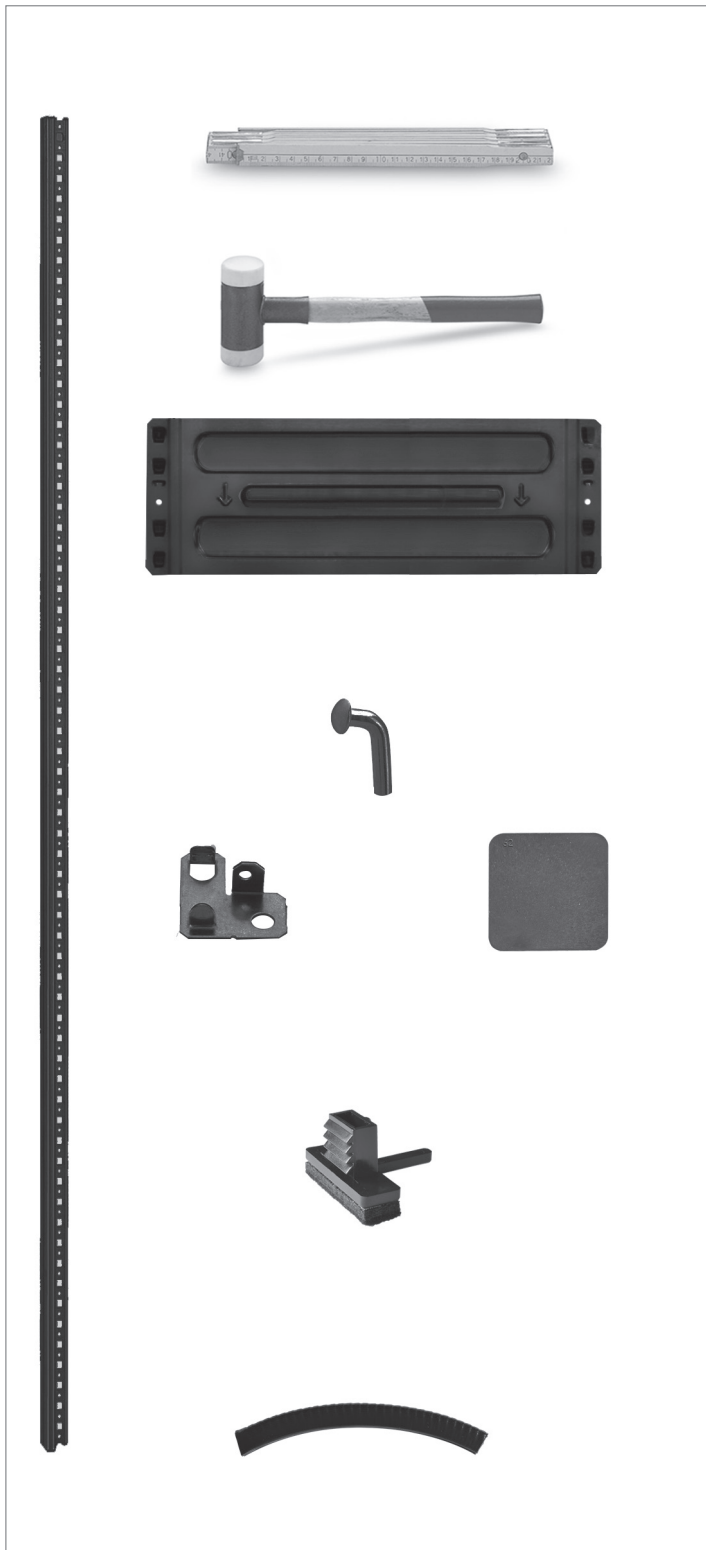

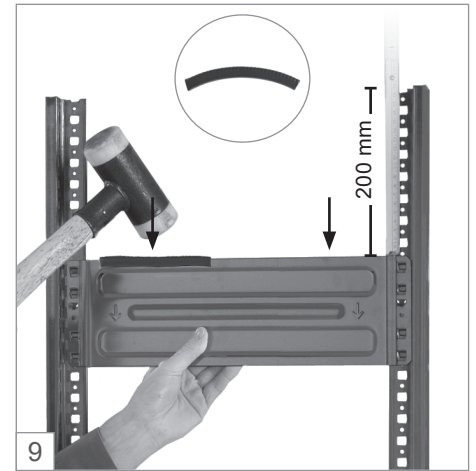

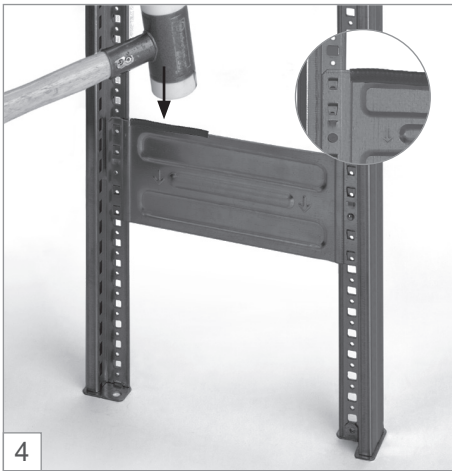
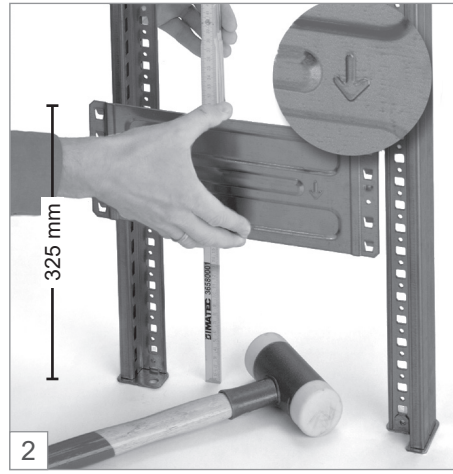
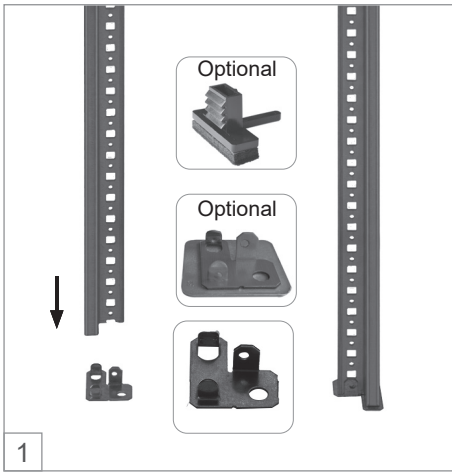
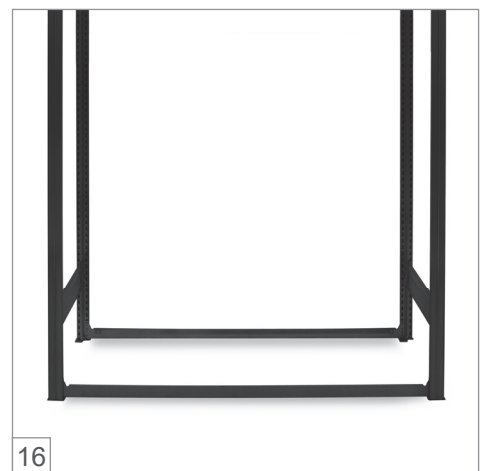
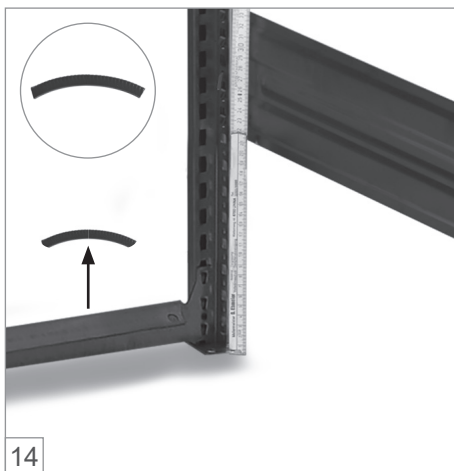
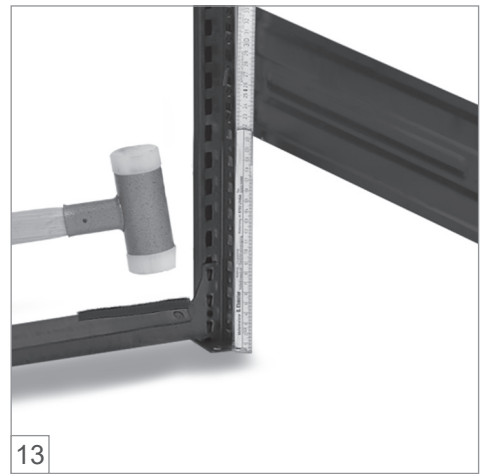
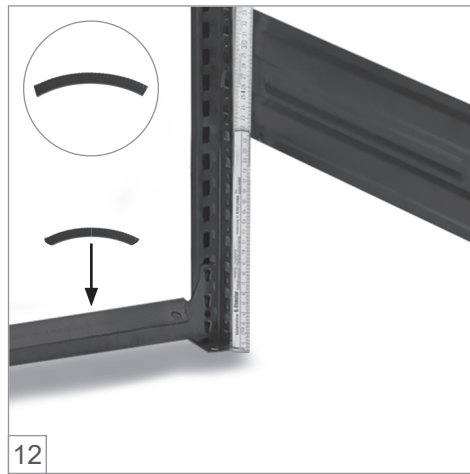
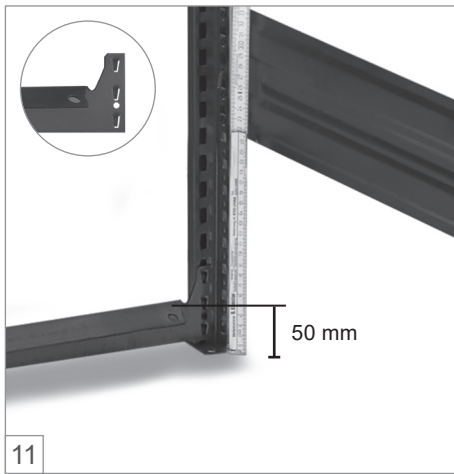
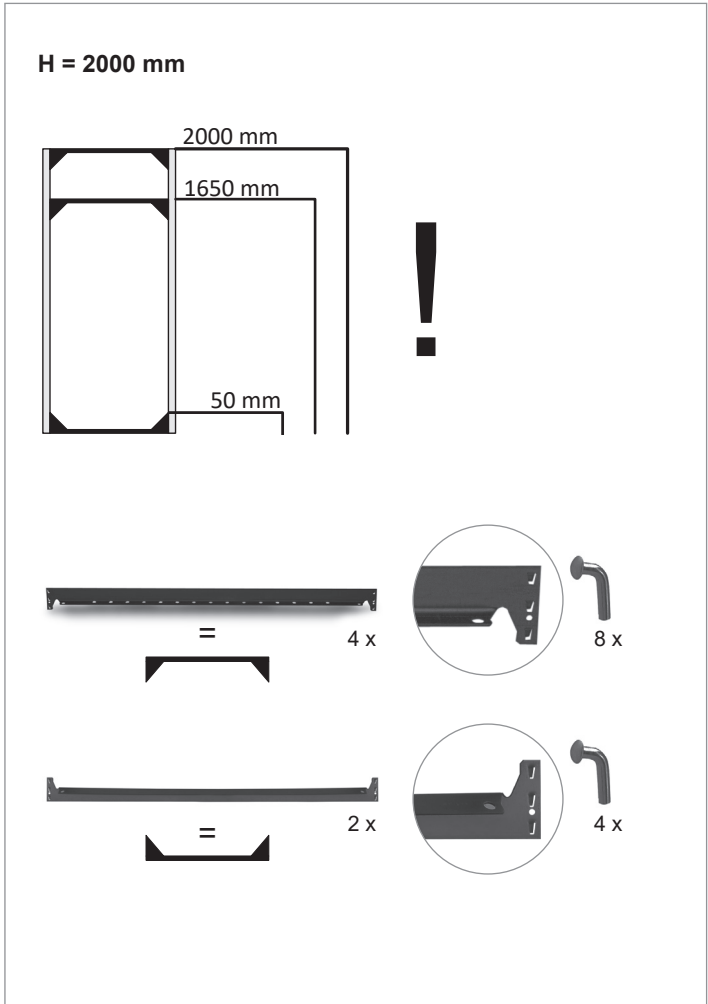
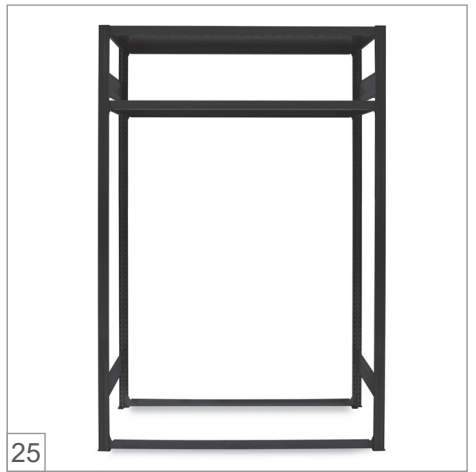
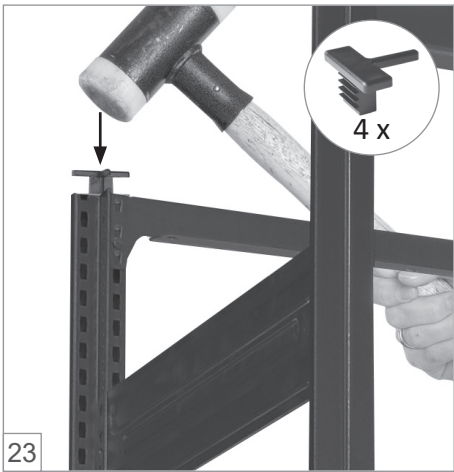
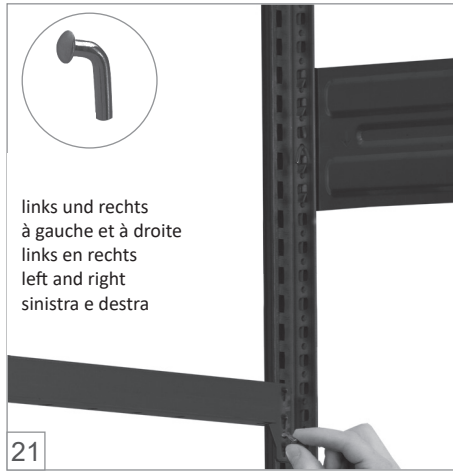
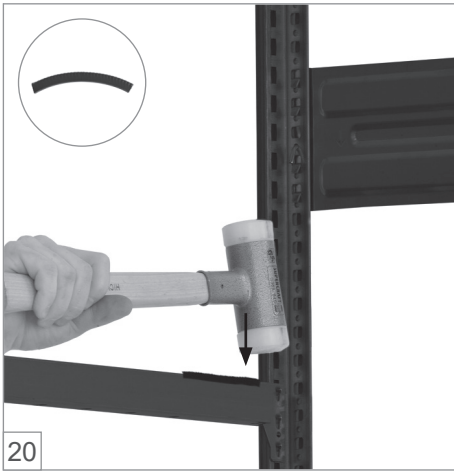
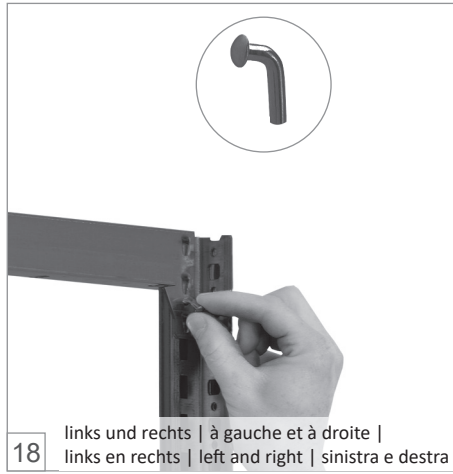

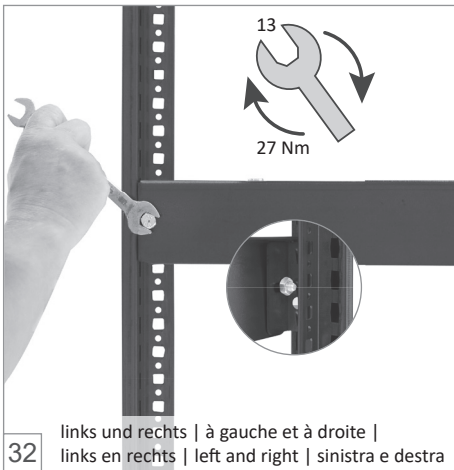
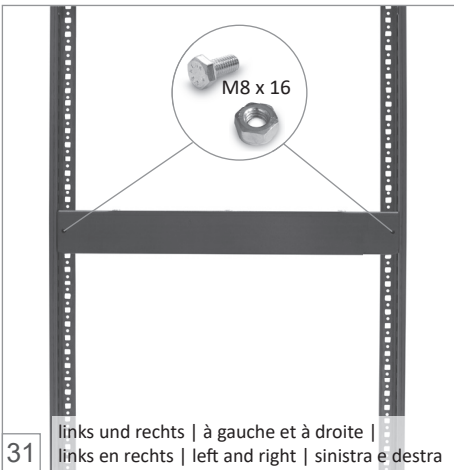
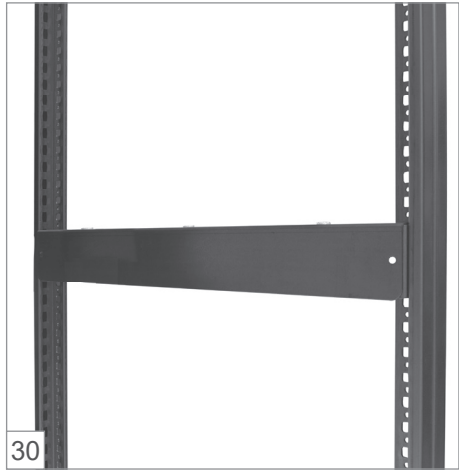
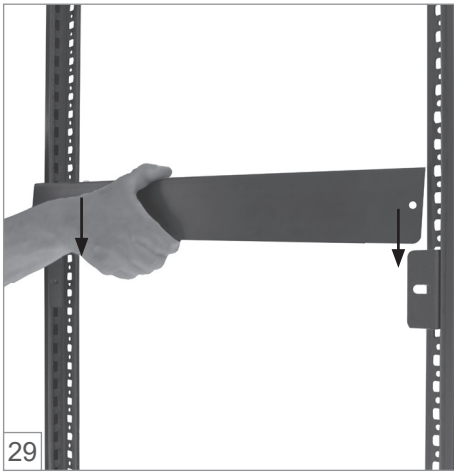
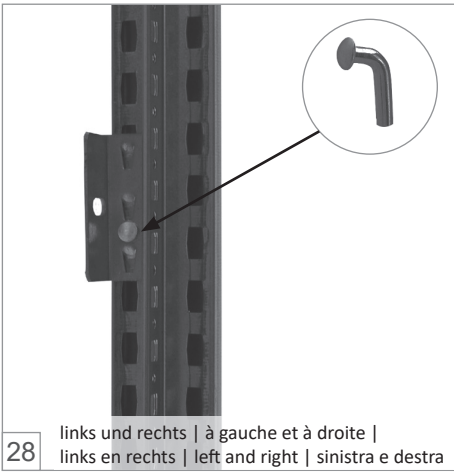
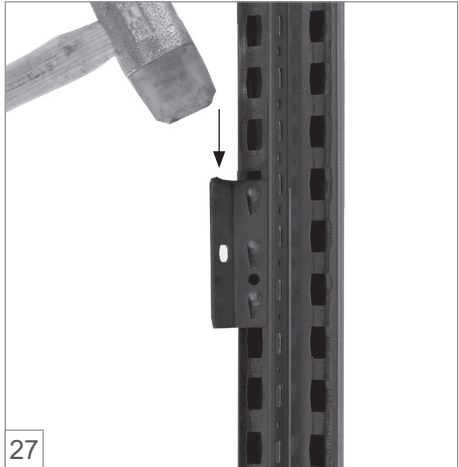
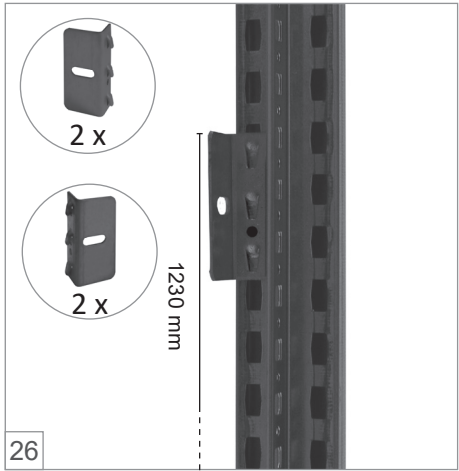
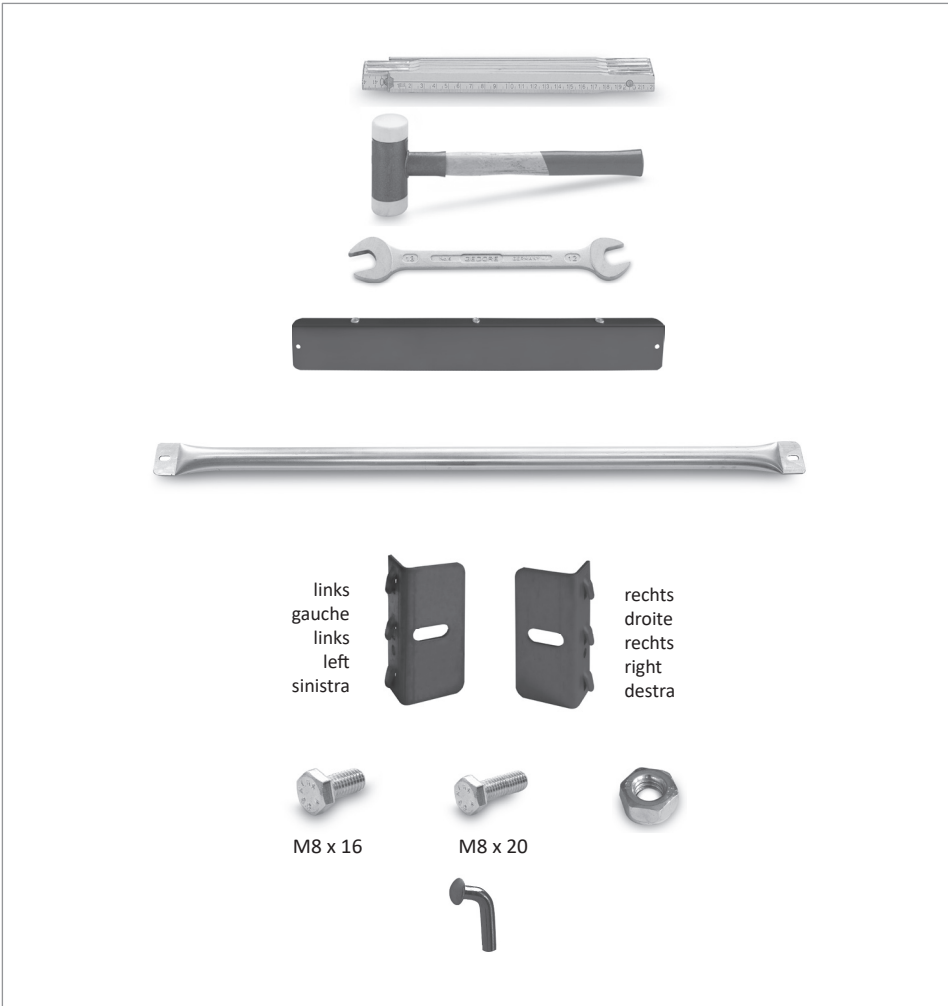

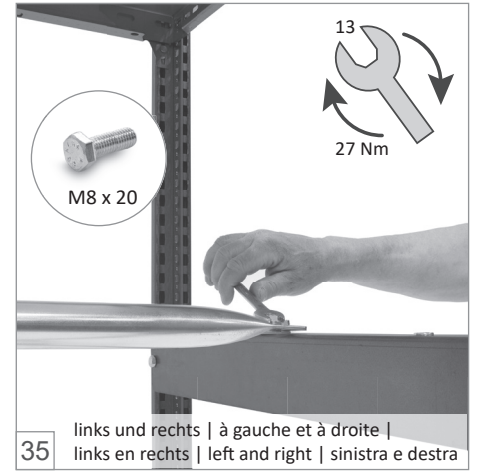

- D ■ Betriebsanleitung
- F ■ Notice d' utilisation
- NL ■ Gebruiksaanwijzing
- GB ■ Instruction for Use

- Wichtige technische Hinweise
- Remarque technique importante
- Belangrijke technische aanwijzingen
- Important technical information

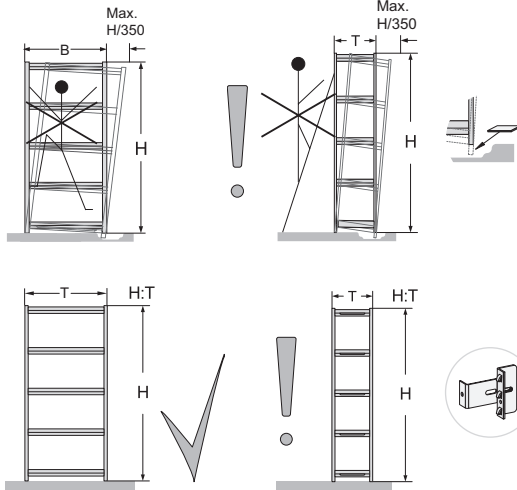

- D Beachten Sie bitte, dass die Stützrahmen senkrecht stehen. Eine Abweichung um ein Dreihundertfünftzigstel der Höhe kann toleriert werden, ggf. sind Unterlegplatten erforderlich. Als standsicher gelten von Hand be- und entladene Regale, wenn der Wert: Höhe geteilt durch Tiefe kleiner oder gleich 5 ist. Falls das Ergebnis größer als 5 ist, sind die Regale durch geeignete Maßnahmen zu sichern (DGUV-I 208-061). Sollten Sie bezüglich der erforderlichen Sicherungen Fragen haben, rufen Sie uns bitte an.
- F Veillez à ce que les châssis d'appui soient parfaitement verticaux. Un écart de un trois cent cinquantième de la hauteur est admissible, le cas échéant des cales d'épaisseur sont indispensables. On considère que des étagères (dé) chargées à la main sont stables si la hauteur divisée par la profondeur est plus petite ou égale à 4 (DIN EN 15635). Si le résultat de cette division est plus grand que 4, il faut prendre des mesures appropriées afin de stabiliser les étagères. Si vous avez des questions au sujet des sécurités requises, n'hésitez pas à nous contacter.
- NL Gelieve ervoor te zorgen dat de steunframes loodrecht staan. Een afwijking van H/350 kan worden getolereerd, evt. zijn er onderlegplaten nodig. Met de hand in- en uitgeladen rekken gelden als stabiel, als de waarde: hoogte gedeeld door diepte kleiner dan of gelijk aan 4 is (DIN EN 15635). Indien het resultaat groter dan 4 is, moeten de rekken door gepaste maatregelen worden verstevigd. Indien u vragen zou hebben gelieve ons op te bellen.
- GB Please make sure that the support frames are vertical. A deviation of a three hundred and fiftieths of the height can be tolerated; shims may be necessary. Shelves which can be loaded and unloaded by hand are considered to be stable when the value of: the height divided by the depth is less than or equal to 4 (DIN EN 15635). The shelves need to be suitably secured if the value is greater than 4. Don't hesitate to ring us for any questions you may have about the type of securing required.
- I Prestare attenzione al fatto che i telai di supporto siano a piombo. Lo scarto non deve essere superiore a H/350. Eventualmente occorrono gli spessori. Gli scaffali carichi / scaricati manualmente risultano stabili quando il rapporto H:T è inferiore rispetto a 4:1. È altrimenti necessario adottare misure di sicurezza speciali (DIN EN 15635). L'utilizzo degli scaffali per mezzo di scale di movimentazione o ad aggancio è fondamentalmente vietato senza adottare particolari misure di sicurezza e senza un controllo di stabilità.

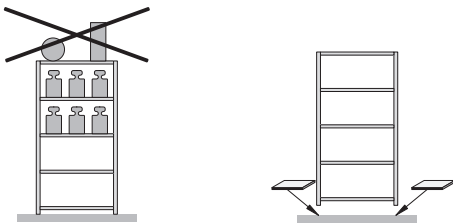

- D Deckböden ohne seitliche Absturzicherung sind ungeeignet zur Lagergutablage. Bei unterschiedlichen Fachlasten sollten die höheren Lasten im unteren Bereich des Regals konzentriert werden. Der Betreiber muss gewährleisten, dass der Fußboden die Lasten aus dem Stützrahmen sicher aufnehmen kann. Die Fußbodenbeschaffenheit muss den Forderungen der DIN 18202 Pkt. 4, Tab. 3, Zeile 3 entsprechen. Ist der Fußboden magnesitgebunden, müssen Kunststoffplatten unterlegt werden.
- F Les tablettes supérieures sans protection latérale contre les chutes ne sont pas adaptés au stockage. Dans le cas de stockage de poids différent, il faut placer les marchandises les plus lourdes en bas. L'exploitant doit garantir que les étagères supportent la charge portée sur le châssis de soutien. La qualité du sol doit correspondre aux exigences de la DIN 18202 point 4, tab. 3 ligne 3. Si le sol est magnésité, il faut placer des plaques plastiques en dessous.
- NL Hed bovenste legbord dient als afdekplaat en mag in principe slechts belast worden als de er op liggende goederen beveiligd worden tegen het naar beneden vallen. Bij verschillende belasting van de leggers moet de grootste belasting in het onderste bereik van de stelling geconcentreerd worden. De exploitant moet waarborgen dat de legger de belasting uit het steunframe zeker kan dragen. De kwaliteit van de vloer moet beantwoorden aan de eisen van DIN 18202 pnt. 4, tab. 3, regel 3. Als het om een magnesietvloer gaat, dan moeten er kunststofplaten onder gelegd worden.
- GB Top shelves without side barriers are unsuitable as storage space. In the event of differences in the load exerted on the various compartments, the heavier loads should be concentrated in the bottom area of the shelving. The user must make sure that the compartment floor is able to safely absorb the loads emanating from the support frame. The condition of the floor must comply with the specifications laid down in DIN 18202 point 4, table 3, line 3. If the floor has been bonded with magnesia cement, plastic boards are to be placed underneath the shelving.
- I I ripiani privi di protezioni laterali contro eventuali cadute non sono adatti per essere impiegati come spazio per lo stoccaggio di materiali. In caso di carichi diversi, i pesi maggiori dovrebbero concentrarsi negli spazi inferiori delle librerie. L'utente deve assicurarsi che il pavimento riesca a sopportare in maniera sicura i carichi dei telai di supporto. Le proprietà del pavimento devono soddisfare i requisiti della normativa DIN 18202 punto 4, tabella 3, riga 3. Se il pavimento contiene magnesite, è necessario disporre delle piastre di plastica sotto ai piedini dello scaffale.

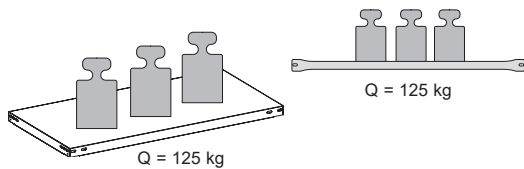

- D Die angegebenen maximalen Tragfähigkeiten für Fachböden [Q] gelten bei jeweils gleichmässig verteilter Last. Die Summe der Fachlasten [ΣQ] in einem Regalfeld muss kleiner/gleich der unten angegebenen Feldlast [Qmax.] sein. Der Gesamtschwerpunkt darf in jedem Fall nicht über der halben Regalhöhe liegen.
- F Les données maximales de support de charge pour sols spéciaux [Q] sont valables dans le cas d'un partage régulier de la charge. La somme des charges spéciales [ΣQ] sur un plan d'étagère doit être égale ou inférieure au poids/surface [Qmax.]. La totalité de la charge ne doit en aucun cas dépasser la moitié de la hauteur.
- NL Het opgegeven maximale draagvermogen voor leggers [Q] geldt bij telkens gelijkmatig verdeelde belasting. De som van de belasting van de leggers [ΣQ] in één stellingveld moet kleiner of gelijk zijn aan de onderstaande veldbelasting [Qmax.]. Het algemene zwaartepunt mag in elk geval niet boven de helft van de stellinghoogte liggen.
- GB The maximum carrying loads listed for compartment floors [Q] apply when the load is evenly distributed in each case. The sum of compartment loads [ΣQ] in a shelf bay must be smaller or equivalent to the bay load [Qmax.] stated below. The overall centre of gravity must not under any circumstances be above half the height of the shelving.
- I Le capacità di carico massime specificate per i ripiani [Q] hanno valore nel caso in cui il carico sia uniformemente ripartito. La somma dei carichi degli scomparti [ΣQ] nella campata dello scaffale deve essere minore o uguale al carico della campata indicato di seguito [Qmax.]. Montando meno di 3 campate dello scaffale si riduce del 10% il carico della campata indicato. Il baricentro generale non deve trovarsi in nessun caso sopra alla metà dell'altezza dello scaffale.

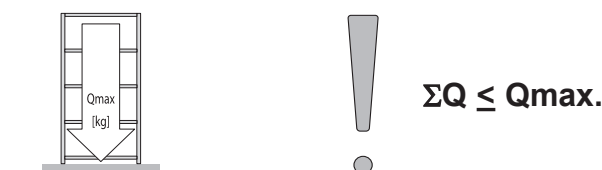
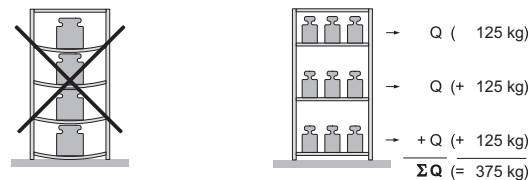

H [mm]	Q [kg]	Q max. [kg]
Höhe Hauteur Hoogte Height Altezza	Fachlast Charge par panneau Loketlast Shelf loading Carico per ripiano	Feldlast Charge par champ Veldbelasting Bay loading Carico per campo
2000 mm	125 kg	500 kg